

2018

**Pennsylvania
Alternative
Residential
Energy
Provisions**



**PENNSYLVANIA HOUSING
RESEARCH CENTER**

This page left intentionally blank for printing.

2018

Pennsylvania Alternative Residential Energy Provisions

The Pennsylvania Housing Research Center
University Park, Pennsylvania



PennState
College of Engineering

**PENNSYLVANIA HOUSING
RESEARCH CENTER**

© 2018 by the Pennsylvania Housing Research Center (PHRC)

All rights reserved. For more information, contact the Pennsylvania Housing Research Center, 206B Sackett Building, University Park, PA 16802.

Published October 2018, Second Edition

Printed in the United States of America

DISCLAIMER: The Pennsylvania Housing Research Center (PHRC) serves the home building industry and the residents of Pennsylvania by improving the quality and affordability of housing. The PHRC conducts applied research, fosters the development and commercialization of innovative technologies, and transfers appropriate technologies to the housing community. The PHRC is housed within the Department of Civil & Environmental Engineering at Penn State. The PHRC conducts operations with the support of numerous agencies, associations, companies, and individuals. Neither the PHRC, nor any of its supporters, makes any warranty, expressed or implied, as to the accuracy or validity of the information contained in this document. Similarly, neither the PHRC, nor its sponsors, assumes any liability for the use of the information and procedures provided in this document. Opinions, when expressed, are those of the authors and do not necessarily reflect the views of either the PHRC or anyone of its sponsors. It would be appreciated, however, if any errors of fact or interpretation or otherwise, could be promptly brought to the attention of PHRC. If additional information is required, contact:

Brian Wolfgang
Associate Director
PHRC
206C Sackett Building
University Park, PA 16802

ACKNOWLEDGMENTS

The development of the 2018 Pennsylvania Alternative Residential Energy Provisions (PA-Alt) was led by the PHRC with guidance from a subcommittee of the PHRC Industry Advisory Council. The PHRC would like to recognize the following members of the PA-Alt Subcommittee for their contribution of time and knowledge:

Bob Hart	Amy Martino
John Holahan	Tom McCosby
Jon Kautz	Sarah Miller
Jerry Leach	Chad Owens
Gary Lenker	Tommy Songer
Robin Loughran	Jon Sukonik
R. Clem Malot	Mike Turns

Financial support for work on the development of this document was provided by the Commonwealth of Pennsylvania and the Pennsylvania Department of Community and Economic Development through funds collected under Act 157 of 2007 and amended by Act 36 of 2017, the Bernard and Henrietta Hankin Chair in Residential Building Construction endowment, the Pennsylvania State University, and the members of the PHRC.

This document was developed by Brian Wolfgang, associate director; Christopher Hine, housing & land development specialist; and Sarah Klinetob Lowe, housing systems specialist of the PHRC. Energy equivalence analysis was performed by Sarah Klinetob Lowe. The document design and formatting was done by Rachel Fawcett, budgets & publications coordinator of the PHRC.

The 2018 Pennsylvania Alternative Residential Energy Provisions were developed by the PHRC as a service to the Pennsylvania Department of Labor and Industry on behalf of all the consumers of housing in Pennsylvania.

This page left intentionally blank for printing.

TABLE OF CONTENTS

1. PREFACE	vii
2. SECTION PA100	1
GENERAL	
3. SECTION PA200	5
CLIMATE ZONES	
4. SECTION PA300	7
BUILDING THERMAL ENVELOPE	
5. SECTION PA400	15
SYSTEMS	
6. SECTION PA500	19
ELECTRICAL POWER AND LIGHTING SYSTEMS	

This page left intentionally blank for printing.

PREFACE

In November 1999, the Pennsylvania Legislature passed Act 45, known as the Uniform Construction Code (UCC), into law mandating a statewide building code across Pennsylvania. Act 45 requires the Pennsylvania Department of Labor and Industry (DLI) to promulgate regulations to implement the requirements of the legislation and in addition, to consider the development of alternative prescriptive methods for energy conservation that account for the various climatic regions within the Commonwealth. In deriving these energy standards, the DLI was to seek to balance energy savings with initial construction costs.

The PHRC developed Pennsylvania Alternative Residential Energy Provisions (PA-Alt) for consideration by DLI to meet their legislated mandate. The PA-Alt was developed with the intent of being:

- simpler to build to and easier to enforce;
- more rational and flexible;
- focused on Pennsylvania in terms of climatic and other conditions; and,
- equivalent to the provisions of the International Energy Conservation Code (IECC).

The initial version of the PA-Alt was developed in 2000 and was based on the 2000 IECC and International Residential Code (IRC). The second, third, and fourth versions were updated to the 2003, 2006, and 2009 IECC and IRC, respectively. This document is the fifth iteration of the PA-Alt, and it is equivalent to the 2015 IECC and IRC.

The Pennsylvania Alternative Residential Energy Provisions document is an alternative to chapter 11 of the IRC. It is intended to supplement the IRC and to the extent possible, be consistent in format and general intent. The scope and definitions used in the IRC apply. It is important to note that a choice needs to be made by the builder or design professional between the 2018 PA-Alt, the 2015 IRC, and the 2015 IECC.

This page left intentionally blank for printing.

SECTION PA100

GENERAL

PA101 Scope. The provisions of this document regulate energy efficiency for the design and construction of buildings regulated by the 2015 International Residential Code (IRC) as incorporated in the PA Uniform Construction Code (UCC) in the Commonwealth of Pennsylvania.

Exception: Portions of the building envelope that do not enclose conditioned space.

PA102 Intent. This document was developed with the intent of being: simpler to build and easier to enforce; more rational and flexible; focused on Pennsylvania in terms of climatic and other conditions; and, equivalent to the provisions of the International Energy Conservation Code (IECC) in terms of energy efficiency as incorporated in the UCC.

PA103 Compliance. Compliance shall be demonstrated by either meeting the requirements of the IECC or the IRC, as incorporated in the UCC, or meeting the requirements of this document. Climate zones from PA201 shall be used in determining the applicable requirements from this document.

PA104 Entrance requirements. This compliance path allows for some reductions in energy efficiency that will allow simplified enforcement and construction. To utilize the PA Alternative Energy Provisions, the building owner or agent must choose at least one of the energy enhancement options in Table PA104.

Table PA104
Energy Enhancement Options

Option	Description	Minimum efficiency by climate zone			
		South (4)	Central (5)	North (6)	
1	Ductless heat pumps	8.5 HSPF	8.5 HSPF	8.5 HSPF	
2	All air ducts located inside the thermal envelope	Compliant	Compliant	Compliant	
3	Solar photovoltaic system installed	1.4 kW	1.7 kW	3.4 kW	
4	Geothermal or water source heat pump installed	Compliant	Compliant	Compliant	
5	Improved efficiency air source heat pump installed	8.7 HSPF	9.0 HSPF	10.0 HSPF	
6	Improved efficiency furnace installed	90 AFUE	90 AFUE	90 AFUE	
7	Exterior continuous insulation	R20+10	R20+10		
8	Improved airtightness	3.0 ACH50	3.0 ACH50	3.0 ACH50	
9	Improved efficiency windows	U-factor = 0.25	U-factor = 0.23	U-factor = 0.19	
10	Package: Improved efficiency windows and higher attic R-value with raised heel truss ^a	Windows	U-factor = 0.27	U-factor = 0.25	U-factor = 0.25
		Attic	R-value = 60	R-value = 60	R-value = 60
11	Package: Improved efficiency windows and heat pump water heater	Windows	U-factor = 0.27	U-factor = 0.25	U-factor = 0.23
		Heat Pump Water Heater	Compliant	Compliant	Compliant

Notes:

- a. Full height of uncompressed insulation shall extend over the top plate at the eaves.

PA105 Compliance documents. If this document is used for energy compliance, it must be clearly identified on construction documents or listed on the application for a building permit. Additionally, the option used to meet the entrance requirements in PA104 must be identified.

PA106 Definitions. To minimize confusion, the definitions contained in Chapter 2[RE] of the 2015 IECC or Section N1101.6 of the 2015 IRC apply to this document.

PA107 Identification. Materials, systems, and equipment shall be identified in a manner that will allow a determination of compliance with the applicable provisions of this chapter.

PA108 Building thermal envelope insulation. An R-value identification mark shall be applied by the manufacturer to each piece of building thermal envelope insulation 12 inches (305 mm) or more wide. Alternately, the insulation installers shall provide a certification listing the type, manufacturer and R-value of insulation installed in each element of the building thermal envelope. For blown or sprayed insulation (fiberglass and cellulose), the initial installed thickness, settled thickness, settled R-value, installed density, coverage area and number of bags installed shall be listed on the certification. For sprayed polyurethane foam (SPF) insulation, the installed thickness of the area covered and R-value of installed thickness shall be listed on the certificate. For insulated siding, the R-value shall be labeled on the product's package and shall be listed on the certification. The insulation installer shall sign, date and post the certificate in a conspicuous location on the job site.

PA108.1 Blown or sprayed roof/ceiling insulation. The thickness of blown in or sprayed roof/ceiling insulation (fiberglass or cellulose) shall be written in inches (mm) on markers that are installed at least one for every 300 ft² (28 m²) throughout the attic space. The markers shall be affixed to the trusses or joists and marked with the minimum initial installed thickness with numbers a minimum of 1 inch (25 mm) high. Each marker shall face the attic access opening. Spray polyurethane foam thickness and installed R-value shall be listed on the certificate provided by the insulation installer.

PA108.2 Insulation mark installation. Insulating materials shall be installed such that the manufacturer's R-value mark is readily observable upon inspection.

PA109 Fenestration product rating. U-factors of fenestration products (windows, doors and skylights) shall be determined in accordance with NFRC 100 by an accredited, independent laboratory, and labeled and certified by the manufacturer. Products lacking such a labeled U-factor shall be assigned a default U-factor from 2015 IRC Tables N1101.10.3(1) [R303.1.3(1)] and N1101.10.3(2) [R303.1.3(2)].

PA110 Insulation product rating. The thermal resistance (R-value) of insulation shall be determined in accordance with the CFR Title 16, Part 460, in units of h ft² °F/Btu at a mean temperature of 75°F (24°C), installer shall sign, date and post the certificate in a conspicuous location on the job site.

PA110.1 Insulated Siding. The thermal resistance (R-value) of insulated siding shall be determined in accordance with ASTM C1363. Installation for testing shall be in accordance with the manufacturer's installation instructions.

PA111 Installation. All materials, systems and equipment shall be installed in accordance with the manufacturer's installation instructions and the provisions of this code.

PA111.1 Protection of exposed foundation insulation. Insulation applied to the exterior of basement walls, crawl space walls, and the perimeter of slab-on-grade floors shall have a rigid, opaque and weather-resistant protective covering to prevent the degradation of the insulation's thermal performance. The protective covering shall cover the exposed exterior insulation and extend a minimum of 6 inches (152 mm) below grade.

PA112 Maintenance information. Maintenance instructions shall be furnished for equipment and systems that require preventative maintenance. Required regular maintenance actions shall be clearly stated and

incorporated on a readily accessible label. The label shall include the title or publication number for the operation and maintenance manual for that particular model and type of product.

PA113 Above code programs. The building official or other authority having jurisdiction shall be permitted to deem a national, state or local energy efficiency program to exceed the energy efficiency required by this document. Buildings approved in writing by such an energy efficiency program shall be considered in compliance with this document.

PA114 Certificate. A permanent certificate shall be posted on or in the electrical distribution panel. The certificate shall not cover or obstruct the visibility of the circuit directory label, service disconnect label or other required labels. The certificate shall be completed by the builder or registered design professional. The certificate shall list the predominant R-values of insulation installed in or on ceiling/roof, walls, foundation (slab, basement wall, crawlspace wall and/or floor) and ducts outside conditioned spaces; U-factors for fenestration; and the solar heat gain coefficient (SHGC) of fenestration. Where there is more than one value for each component, the certificate shall list the value covering the largest area.

The certificate shall list the types and efficiencies of heating, cooling and service water heating equipment. Where a gas-fired unvented room heater, electric furnace and/or baseboard electric heater is installed in the residence, the certificate shall list "gas-fired unvented room heater," "electric furnace" or "baseboard electric heater," as appropriate. An efficiency shall not be listed for gas-fired unvented room heaters, electric furnaces or electric base board heaters.

This page left intentionally blank for printing.

SECTION PA200

CLIMATE ZONES

PA201 General. Climate zones listed in PA201.1 shall be used.

PA201.1 Climate Zones

South (4): Bucks, Chester, Delaware, Montgomery, Philadelphia, York

Central (5): All other counties

North (6): Cameron, Clearfield, Elk, McKean, Potter, Susquehanna, Tioga, Wayne

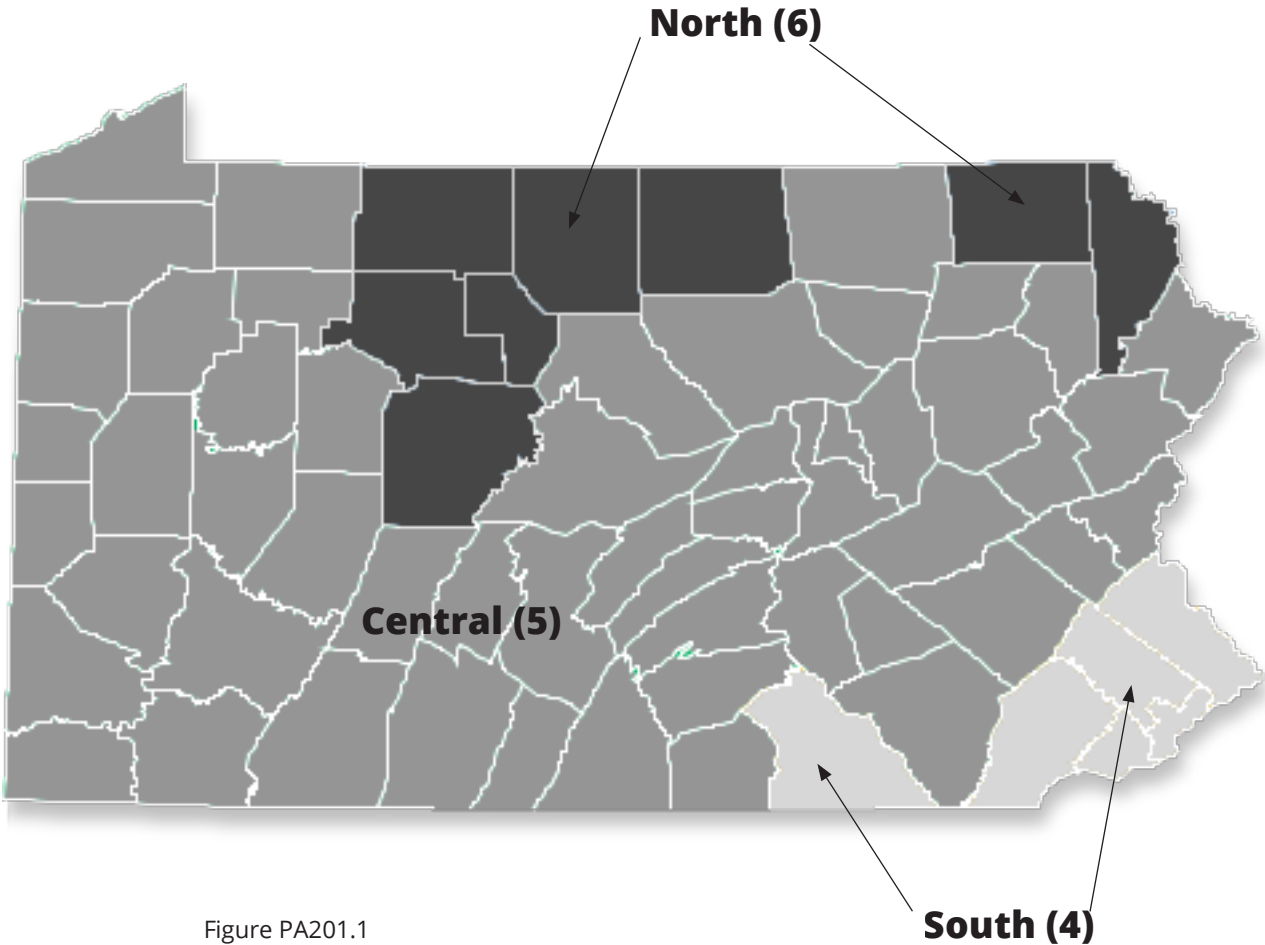

Figure PA201.1
Pennsylvania Climate Zones

Image Source: <https://energycode.pnl.gov/EnergyCodeReqs/?state=Pennsylvania>

This page left intentionally blank for printing.

SECTION PA300

BUILDING THERMAL ENVELOPE

PA301 Insulation and fenestration criteria. The building thermal envelope shall meet the requirements of Table PA301 based on the climate zone specified in PA201.

PA301.1 R-value computation. Insulation material used in layers, such as framing cavity insulation and insulating sheathing, shall be summed to compute the component R-value. The manufacturer's settled R-value shall be used for blown insulation. Computed R-values shall not include an R-value for other building materials or air films. Where insulated siding is used for the purpose of complying with the continuous insulation requirements of Table PA301, the manufacturer's labeled R-value for insulated siding shall be reduced by R-0.6.

Table PA301
Insulation and Fenestration Requirements by Component^a

Climate Zone	Fenestration ^b U-factor	Skylights U-factor	Glazed Fenestration SHGC	Ceiling R-value	Wood Frame Wall R-value	Mass Wall R-value ^c	Floor R-value	Basement ^d Wall R-value	Slab ^e R-value and depth	Crawlspace ^d Wall R-value
South (4)	0.35	0.55	0.4	38	20 ^h or 13+5 ^g	8/13	19	10/13	10, 2 ft	10/13
Central (5)	0.32	0.55	NR	49	20 ^h or 13+5 ^g	13/17	30 ^f	10/13	10, 2 ft	10/13
North (6)	0.32	0.55	NR	49	23, 20+5, 18+6.5, or 13+10	15/20	30 ^f	10/13	10, 4 ft	15/19

Notes:

- R-values are minimums. U-factors and solar heat gain coefficient (SHGC) are maximums. R-19 batts compressed in to nominal 2 x 6 framing cavity such that the R-value is reduced by R-1 or more shall be marked with the compressed batt R-value in addition to the full thickness R-value.
- The fenestration U-factor column excludes skylights.
- The second R-value applies when more than half the insulation is on the interior.
- The first R-value applies to continuous insulation on the interior or exterior of the home, the second to framing cavity insulation at the interior of the basement wall; either insulation meets the requirement.
- R-5 shall be added to the required slab edge R-values for heated slabs.
- Or insulation sufficient to fill the framing cavity, R-19 minimum. Floor insulation may also be reduced to R-19 if installed above an unconditioned basement.
- "13 + 5" means R-13 cavity insulation plus R-5 insulated sheathing. If structural sheathing covers 40% or less of the exterior, continuous insulation R-value shall be permitted to be reduced by no more than R-3 in the locations where structural sheathing is used - to maintain a consistent total sheathing thickness.
- R-18 insulation shall be permitted in place of R-20 requirement provided the wall framing factor is 20% or less or exterior walls with 24" o.c. nominal vertical stud spacing.

PA302 Specific insulation requirements.

PA302.1 Ceilings with attic spaces. When Section PA301 would require R-38 in the ceiling, R-30 shall be deemed to satisfy the requirement for R-38 wherever the full height of uncompressed R-30 insulation extends over the wall top plate at the eaves. Similarly R-38 shall be deemed to satisfy the requirement for R-49 wherever the full height of uncompressed R-38 insulation extends over the wall top plate at the eaves.

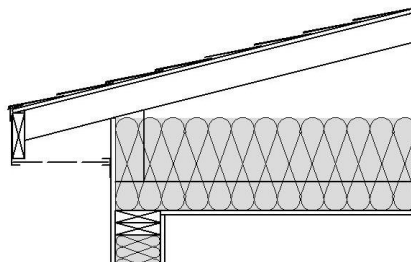

Figure PA302.1
Ceiling With Full-Height Uncompressed Insulation Above the Top Plate

PA302.2 Ceilings without attic spaces. Where the design of the roof/ceiling assembly does not allow sufficient space for the required insulation, such as cathedral ceilings, the minimum required insulation for such roof/ceiling assemblies shall be R-30.

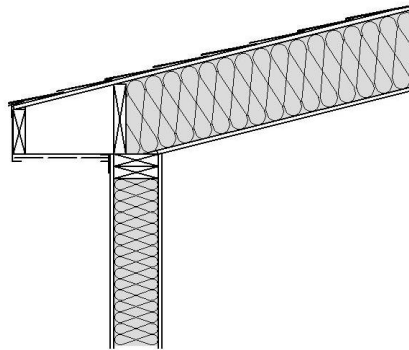

Figure PA302.2
Ceiling Without Attic Spaces

PA302.3 Access hatches and doors. Access hatches and doors from conditioned spaces to unconditioned spaces (e.g., attics and crawl spaces) shall be weather stripped. Both vertical and horizontal access hatches shall be insulated to a minimum of R-20 with rigid foam permanently attached to the access hatch. This is not intended to restrict the use of proprietary products meeting the intent of this provision. Side hinged access door shall meet the fenestration requirements of Table PA301.

A wood framed or equivalent baffle or retainer is required to be provided when loose fill insulation is installed. The purpose of which is to prevent the loose fill insulation from spilling into the living space when the attic access is opened. Areas around access hatches required to service equipment shall provide a permanent means of maintaining the installed R-value of the insulation.

Exception: Vertical doors that provide access from conditioned to unconditioned spaces shall be permitted to meet the fenestration requirements of Table PA301 based on the applicable climate zone specified in section PA201.1.

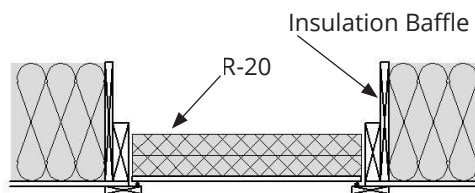

Figure PA302.3 (1)
Attic Hatch

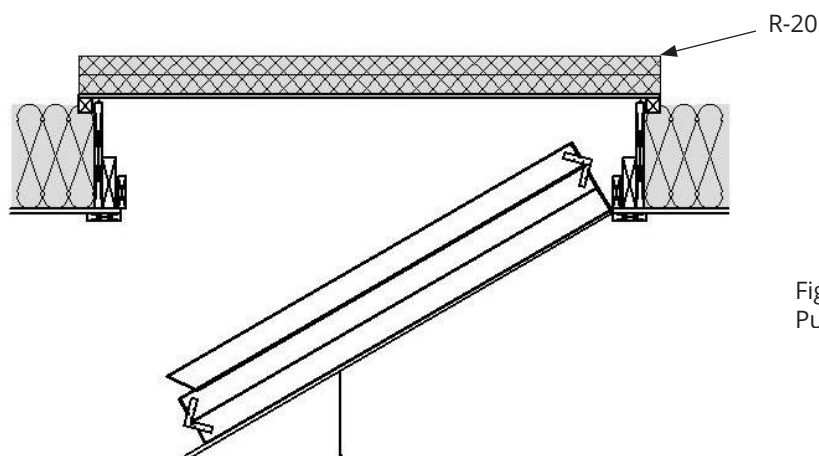

Figure PA302.3 (2)
Pull-Down Stairs

PA302.4 Mass walls. Mass walls, for the purposes of this chapter, shall be considered above-grade walls of concrete block, concrete, insulated concrete form (ICF), masonry cavity, brick (other than brick veneer), earth (adobe, compressed earth block, rammed earth) and solid timber/logs, or any other walls having a heat capacity greater than or equal to 6 Btu/ft²·x°F (123 kJ/m²·xK)

PA302.5 Floors. Floor insulation shall be installed to maintain permanent contact with the underside of the subfloor decking.

Exception: The floor framing-cavity insulation shall be permitted to be in contact with the topside of sheathing or continuous insulation installed on the bottom side of floor framing where combined with insulation that meets or exceeds the minimum wood frame wall R-value in Table PA301 and that extends from the bottom to the top of all perimeter floor framing members.

PA302.6 Basement walls. Exterior walls associated with conditioned basements shall be insulated from the top of the basement wall down to 10 feet (3048 mm) below grade or to the basement floor, whichever is less. Walls associated with unconditioned basements shall meet this requirement unless the floor overhead is insulated in accordance with Sections PA301.

PA302.7 Slab-on-grade floors. Slab-on-grade floors with a floor surface less than 12 inches (305 mm) below grade shall be insulated in accordance with Table PA301. The insulation can be installed on either the exterior or interior of the foundation wall.

PA302.7.1 Exterior Insulation. Exterior insulation shall be installed from the top of the slab and extend below grade the distance listed in Table PA301 by any combination of vertical insulation or horizontal insulation extending away from the building. Insulation extending away from the building shall be protected by pavement or by a minimum of 10 inches (254 mm) of soil. Insulation shall also meet PA 111.1.

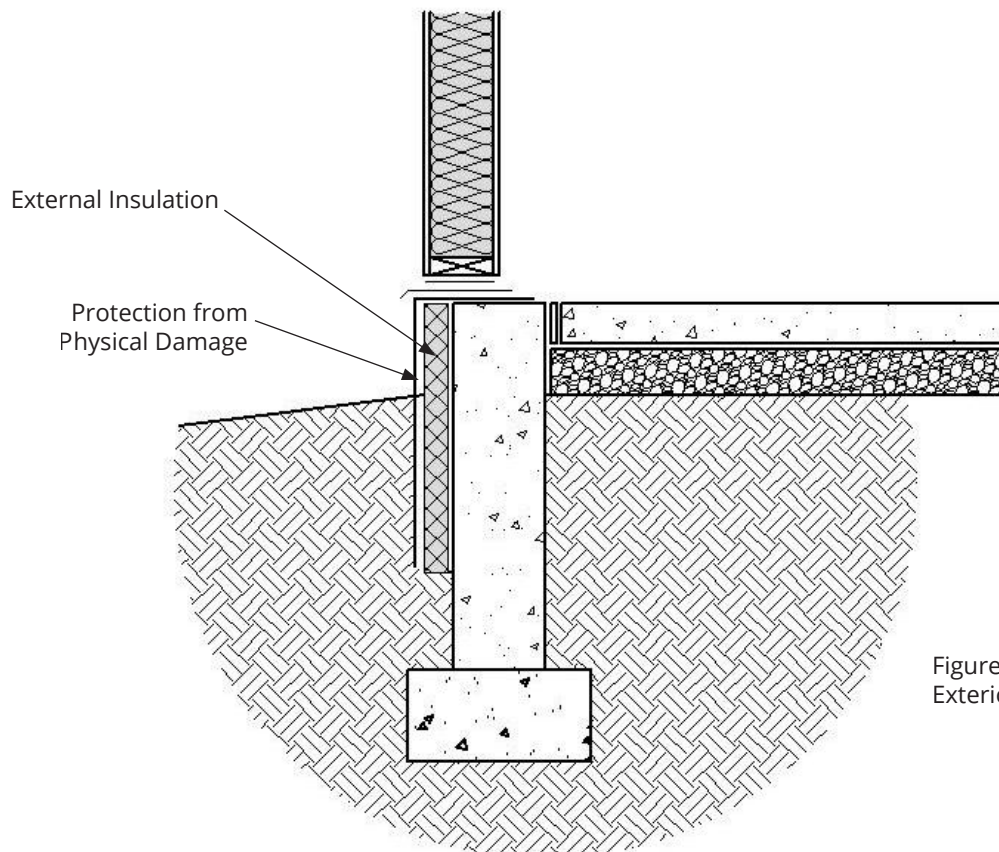

Figure PA302.7.1
Exterior Slab Insulation

PA302.7.2 Interior Insulation. Interior insulation shall be installed from the bottom of the slab and extend the distance provided in Table PA301 by any combination of vertical insulation or horizontal insulation extending under the slab. The slab edge shall be separated from the foundation wall by a continuous ½ inch thermal break as per Figure PA302.8.(2) A thermal break shall be created by a material suitable for ground contact, which includes, but is not limited to, asphalt impregnated fiber board or extruded polystyrene. Slab-edge insulation is not required in jurisdictions designated by the code official as having a very heavy termite infestation.

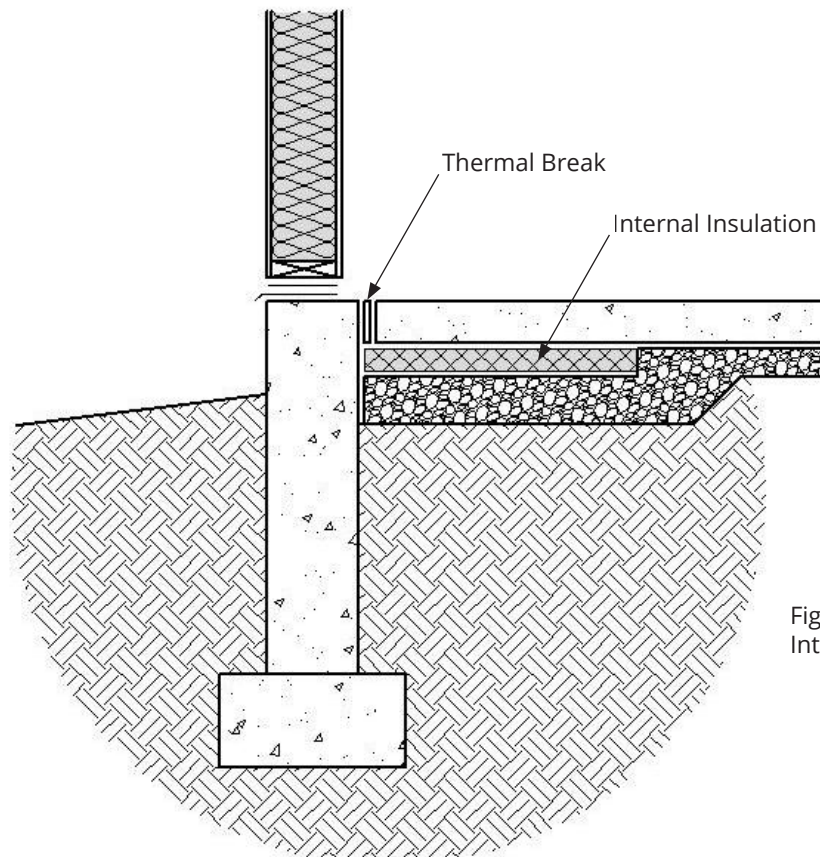

Figure PA302.7.2
Interior Slab Insulation

PA302.8 Crawl space walls. As an alternative to insulating floors over crawl spaces, insulation of crawl space walls shall be permitted when the crawl space is not vented to the outside. Crawl space wall insulation shall be permanently fastened to the wall and extend downward from the floor to the finished grade level and then vertically and/or horizontally for at least an additional 24 inches (610 mm). Exposed earth in unvented crawl space foundations shall be covered with a continuous Class I vapor retarder. All joints of the vapor retarder shall overlap by 6 inches (152 mm) and be sealed or taped. The edges of the vapor retarder shall extend at least 6 inches (152 mm) up the stem wall and shall be attached to the stem wall.

PA302.9 Masonry veneer. Insulation shall not be required on the horizontal portion of the foundation that supports a masonry veneer.

PA302.10 Thermally isolated sunroom insulation. The minimum ceiling insulation R-values shall be R-24. The minimum wall R-value shall be R-13. New wall(s) separating the sunroom from conditioned space shall meet the building thermal envelope requirements.

PA303 Fenestration.

PA303.1 U-factor. An area-weighted average of fenestration products shall be permitted to satisfy the U-factor requirements.

PA303.2 Glazed Fenestration SHGC. An area-weighted average of fenestration products more than 50% glazed shall be permitted to satisfy the SHGC requirements.

PA303.3 Glazed fenestration exemption. Up to 15 square feet (1.4 m²) of glazed fenestration per dwelling unit shall be permitted to be exempt from U-factor requirements Table PA301.

PA303.4 Opaque door exemption. One door assembly, including side hinged opaque doors, sidelights and transoms, up to 54 square feet (5.02 m²) in area is exempted from the U-factor requirement in Table PA301.

PA303.5 Thermally isolated sunroom U-factor. Maximum fenestration U-factor shall be 0.45 and the maximum skylight U-factor shall be 0.70. New windows and doors separating the sunroom from conditioned space shall meet the building thermal envelope requirements.

PA303.6 Replacement fenestration. Where some or all of an existing fenestration unit is replaced with a new fenestration product, including sash and glazing, the replacement fenestration unit shall meet the applicable requirements for U-factor in Table PA301.

PA304 Air leakage.

PA304.1 Building thermal envelope. The building thermal envelope shall be durably sealed to limit infiltration. The sealing methods between dissimilar materials shall allow for differential expansion and contraction.

PA304.1.1. Installation. The components of the building thermal envelope as listed in Table PA304.1.1 shall be installed in accordance with the manufacturer's instructions and the criteria listed in Table PA304.1.1, as applicable to the method of construction. Where required by the building official, an approved third party shall inspect all components and verify compliance.

PA304.1.2 Testing. The building or dwelling unit shall be tested and verified as having an air leakage rate or not exceeding five air changes per hour. Testing shall be conducted in accordance with RESNET/ICC 380, ASTM E 779, or ASTM E 1827 and reported at a pressure of 0.2 inches w.g. (50 Pascals). Where required by the code official, testing shall be conducted by an approved third party. A written report of the results of the test shall be signed by the party conducting the test and provided to the code official. Testing shall be performed at any time after the creation of all penetrations of the building thermal envelope.

During testing:

1. Exterior windows and doors, fireplace and stove doors shall be closed, but not sealed, beyond the intended weatherstripping or other infiltration control measures.
2. Dampers shall be closed, but not sealed beyond intended infiltration control measures; including exhaust, intake, makeup air, back draft, and flue dampers;
3. Interior doors, if installed at the time of test, shall be open;
4. Exterior openings for continuous ventilation systems and heat recovery ventilators shall be closed and sealed;
5. Heating and cooling system(s), if installed at the time of the test, shall be turned off;
6. Supply and return registers, if installed at the time of the test, shall be fully open.

Table PA 304.1.1
Air Barrier and Insulation Installation

Component	Air Barrier Criteria	Insulation Installation Criteria
General requirements	<p>A continuous air barrier shall be installed in the building envelope.</p> <p>The exterior thermal envelope contains a continuous air barrier.</p> <p>Breaks or joints in the air barrier shall be sealed.</p>	<p>Air-permeable insulation shall not be used as a sealing material.</p>
Ceiling / attic	<p>The air barrier in any dropped ceiling / soffit shall be aligned with the insulation and any gaps in the air barrier sealed.</p> <p>Access openings, drop down stairs or knee wall doors to unconditioned attic spaces shall be sealed.</p>	<p>The insulation in any dropped ceiling / soffit shall be aligned with the air barrier.</p>
Walls	<p>The junction of the foundation and sill plate shall be sealed.</p> <p>The junction of the top plate and the top of exterior walls shall be sealed.</p> <p>Knee walls shall be sealed.</p>	<p>Cavities within corners and headers of frame walls shall be insulated by completely filling the cavity with a material having a thermal resistance of R-3 per inch minimum.</p> <p>Exterior thermal envelope insulation for framed walls shall be installed in substantial contact and continuous alignment with the air barrier.</p>
Windows, skylights and doors	<p>The space between window / door jambs and framing, and skylights and framing shall be sealed.</p>	
Rim joists	<p>Rim joists shall include the air barrier.</p>	<p>Rim joists shall be insulated.</p>
Floors (including above garage and cantilever floors)	<p>The air barrier shall be installed at any exposed edge of insulation.</p>	<p>Floor framing cavity insulation shall be installed to maintain permanent contact with the underside of subfloor decking, or floor framing cavity insulation shall be permitted to be in contact with the top side of sheathing, or continuous insulation installed on the underside of floor framing; and extends from the bottom to the top of all perimeter floor framing members.</p>
Crawl space walls	<p>Exposed earth in unvented crawl space shall be covered with a Class I vapor retarder with overlapping joints taped.</p>	<p>Where provided instead of floor insulation, insulation shall be permanently attached to the crawl space walls.</p>
Shafts, penetrations	<p>Duct shafts, utility penetrations, and flue shafts opening to exterior or unconditioned space shall be sealed.</p>	
Narrow cavities		<p>Batts in narrow cavities shall be cut to fit, or narrow cavities shall be filled by insulation that on installation readily conforms to the available cavity space.</p>
Garage separation	<p>Air sealing shall be provided between the garage and conditioned spaces.</p>	
Recessed lighting	<p>Recessed light fixtures installed in the building thermal envelope shall be sealed to the drywall.</p>	<p>Recessed light fixtures installed in the building thermal envelope shall be air tight and IC rated.</p>
Plumbing and wiring		<p>Batt insulation shall be cut neatly to fit around wiring and plumbing in exterior walls, or insulation that on installation readily conforms to available space shall extend behind piping and wiring</p>
Shower / tub on exterior wall	<p>The air barrier installed at exterior walls adjacent to shower and tubs shall separate them from the shower and tubs</p>	<p>Exterior walls adjacent to showers and tubs shall be insulated.</p>
Electrical / phone box on exterior walls	<p>The air barrier shall be installed behind electrical or communication boxes or air-sealed boxes shall be installed.</p>	
HVAC register boots	<p>HVAC register boots that penetrate building thermal envelope shall be sealed to the subfloor or drywall.</p>	
Concealed Sprinklers	<p>When required to be sealed, concealed fire sprinklers shall only be sealed in a manner that is recommended by the manufacturer.</p> <p>Caulking or other adhesive sealants shall not be used to fill voids between fire sprinkler cover plates and walls or ceilings.</p>	

PA304.2 Fireplaces. New wood-burning fireplaces shall have tight-fitting flue dampers or doors, and outdoor combustion air. Where using tight-fitting doors on factory-built fireplaces listed and labeled in accordance with UL 127, the doors shall be tested and listed for the fireplace. Where using tight-fitting doors on masonry fireplaces, the doors shall be listed and labeled in accordance with UL 907.

PA304.3 Fenestration air leakage. Windows, skylights and sliding glass doors shall have an air infiltration rate of no more than 0.3 cubic foot per minute per square foot [1.5 (L/s)/m²], and swinging doors no more than 0.5 cubic foot per minute per square foot [2.5 (L/s)/m²], when tested according to NFRC400 or AAMA/WDMA/CSA101/I.S.2/A440 by an accredited, independent laboratory, and listed and labeled by the manufacturer.

Exception: Site-built windows, skylights and doors.

PA304.4 Recessed lighting. Recessed luminaires installed in the building thermal envelope shall be sealed to limit air leakage between conditioned and unconditioned spaces. All recessed luminaires shall be IC-rated and labeled as having an air leakage rate not more than 2.0 cfm (0.944 L/s) when tested in accordance with ASTM E283 at a 1.57 psf (75 Pa) pressure differential. All recessed luminaires shall be sealed with a gasket or caulk between the housing and the interior wall or ceiling covering.

This page left intentionally blank for printing.

SECTION PA400

SYSTEMS

PA401 Controls. At least one thermostat shall be installed for each separate heating and cooling system.

PA401.1 Programmable thermostat. The thermostat controlling the primary heating or cooling system of the dwelling unit shall be capable of controlling the heating and cooling system on a daily schedule to maintain different temperature set points at different times of the day. This thermostat shall include the capability to set back or temporarily operate the system to maintain zone temperatures down to 55°F (13°C) or up to 85°F (29°C). The thermostat shall initially be programmed with a heating temperature set point no higher than 70°F (21°C) and a cooling temperature set point no lower than 78°F (26°C).

PA401.2 Heat pump supplementary heat. Heat pumps having supplementary electric-resistance heat shall have controls that, except during defrost, prevent supplemental heat operation when the heat pump compressor can meet the heating load.

PA402 Ducts.

PA402.1 Insulation. Supply and return ducts in attics shall be insulated to a minimum of R-8 where 3 inches (76.2 mm) in diameter and greater and R-6 where less than 3 inches (76.2 mm) in diameter. Supply and return ducts in other portions of the building shall be insulated to a minimum of R-6 where 3 inches (76.2 mm) in diameter or greater and R-4.2 where less than 3 inches (76.2 mm) in diameter.

Exception: Ducts or portions thereof located completely inside the building thermal envelope.

PA402.2 Sealing. Ducts, air handlers, filter boxes and building cavities used as returns shall be sealed. Joints and seams shall comply with either the International Mechanical Code or 2015 IRC Section M1601.4.1.

Exceptions:

1. Air-impermeable spray foam products shall be permitted to be applied without additional joint seals.
2. For ducts having a static pressure classification of less than 2 inches of water column (500 Pa), additional closure systems shall not be required for continuously welded joints and seams and locking-type joints and seams. This exception shall not apply to snap-lock and button-lock type joints and seams that are located outside of conditioned spaces.

PA402.2.1 Sealed air handler. Air handlers shall have a manufacturer's designation for an air leakage of no more than 2% of the design air flow rate when tested in accordance with ASHRAE 193.

PA402.3. Duct testing. Duct tightness shall be verified by either of the following:

Option 1: Post-construction test. Total leakage shall be measured with a pressure differential of 0.1 inch w.g. (25 Pa) across the entire system, including the manufacturer's air handler closure. All register boots shall be taped or otherwise sealed during the test.

Option 2: Rough-in test. Total leakage shall be measured with a pressure differential of 0.1 inch w.g. (25 Pa) across the roughed in system, including the manufacturer's air handler enclosure if installed at the time of test. All register boots shall be taped or otherwise sealed during the test.

Exception: Duct tightness test is not required if the air handler and all ducts are located within conditioned space.

PA402.4. Duct Testing. The total leakage of the ducts, where measured in accordance with section PA402.3, shall be less than or equal to the values shown in Table PA402.4.

Table PA402.4
Duct Leakage Targets

Duct Testing Option	Total Leakage (cfm/100ft ²)
Rough-in with air handler	4
Rough-in without air handler	3
Post-construction	4

PA402.3 Building cavities. Building framing cavities shall not be used as supply ducts.

PA403 Mechanical system piping insulation. Mechanical system piping capable of carrying fluids above 105°F (40°C) or below 55°F (13°C) shall be insulated to a minimum of R-3.

PA403.1 Protection of piping insulation. Piping insulation exposed to weather shall be protected from damage including that caused by sunlight, moisture, equipment maintenance, and wind, and shall provide shielding from solar radiation that can cause degradation of the material. Adhesive tape shall not be permitted.

PA404 Service hot water systems. Energy conservation measures for service hot water systems shall be in accordance with Sections N1103.5.1 through N1103.5.4 of the 2015 IRC, including Pennsylvania Uniform Construction Code amendments.

PA405 Mechanical ventilation. The building shall be provided with mechanical ventilation that meets the requirements of Section M1507 of the 2015 IRC or the International Mechanical Code, as applicable, or with other approved means of ventilation. Outdoor air intakes and exhausts shall have automatic or gravity dampers that close when the ventilation system is not operating.

PA405.1 Whole-house mechanical ventilation system fan efficacy. Mechanical ventilation system fans shall meet the efficacy requirements of Table R405.1.

Exception: Where mechanical ventilation fans are integral to tested and listed HVAC equipment, they shall be powered by an electronically commutated motor.

Table PA405.1
Mechanical Ventilation System Fan Efficacy

Fan Location	Air Flow Rate Minimum (cfm)	Minimum Efficacy (cfm/watt)	Air Flow Rate Maximum (cfm)
Range hoods	Any	2.8	Any
In-line fan	Any	2.8	Any
Bathroom, utility room	10	1.4	< 90
Bathroom, utility room	90	2.8	Any

PA406 Equipment sizing. Heating and cooling equipment shall be sized as specified in Section M1401.3.

PA407 Snow melt system controls. Snow- and ice-melting systems supplied through energy service to the building shall include automatic controls capable of shutting off the system when the pavement temperature is above 50°F (10°C) and no precipitation is falling and an automatic or manual control that will allow shutoff when the outdoor temperature is above 40°F (5°C).

PA408 Pools and permanent spa energy consumption. The energy consumption of pools and permanent spas shall be in accordance with Sections PA408.1 through PA408.5.

PA408.1 Heaters. The electric power to heaters shall be controlled by a readily accessible on-off switch that is an integral part of the heater mounted on the exterior of the heater or external to and within 3 feet (914 mm) of the heater. Operation of such switch shall not change the setting of the heater thermostat. Such switches shall be in addition to a circuit breaker for the power to the heater. Gas-fired heaters shall not be equipped with continuously burning ignition pilots.

PA408.2 Time switches. Time switches or other control methods that can automatically turn off and on according to a preset schedule shall be installed for heaters and pump motors. Heaters and pump motors that have built-in time switches shall be in compliance with this section.

Exceptions:

1. Where public health standards require 24-hour pump operation.
2. Where pumps are required to operate solar- and waste-heat-recovery pool heating systems.

PA408.3 Covers. Outdoor heated pools and outdoor permanent spas shall be provided with a vapor retardant cover or other approved vapor retardant means.

Exception: Where more than 70 percent of the energy for heating, computed over an operation season, is from site-recovered energy, such as from a heat pump or solar energy source, covers or other vapor retardant means shall not be equipped.

PA408.4 Portable Spas. The energy consumption of electric-powered portable spas shall be controlled by the requirements of APSP-14.

PA408.5 Residential pools and permanent residential spas. Residential swimming pools and permanent residential spas that are accessory to detached one- and two-family dwellings and townhouses 3 stories or less in height above grade plane and that are available only to the household and its guests shall be in accordance with APSP-15.

This page left intentionally blank for printing.

SECTION PA500

ELECTRICAL POWER AND LIGHTING SYSTEMS

PA501 Lighting equipment. Not less than 75 percent of the lamps in permanently installed lighting fixtures shall be high-efficacy lamps or not less than 75 percent of the permanently installed lighting fixtures shall contain only high-efficacy lamps.

Exception: Low-voltage lighting.

PA501.1. Fuel gas lighting systems. Fuel gas lighting systems shall not have continuously burning pilot lights.

This page left intentionally blank for printing.

This page left intentionally blank for printing.



**PENNSYLVANIA HOUSING
RESEARCH CENTER**

206B Sackett Building
University Park, PA 16802
814-865-2341
Fax: 814-863-7304
www.phrc.psu.edu